

Model DF100 Control Valve

Operation, Parts, and Instruction Manual



Figure 1
DF100 Control Valve

TABLE OF CONTENTS

Introduction	2	Re-Assembly	9
General	2	Bonnet Sub-Assembly	9
Scope	2	Stem Installation	10
Specifications	3	Valve Plug Installation	10
Cv Values - Table 1	3	Seat Ring Installation	10
Max. Shut Off Pressures - Table 2	4	Bonnet Installation	10
FNPT Valve Dimension Diagram - Figure 2	5	Actuator Re-assembly	10
Flanged Valve Dimension Diagram - Figure 3	5	Actuator Conversion	11
RF and RTJ Valve Dimensions - Table 3	6	Packing Diagram - Figure 5	12
Unpacking	6	Fail Open Actuator Cross-Section - Figure 6	13
Installation	6	Fail Open Body Diagram - Figure 7	14
Air Piping	7	Fail Closed Body Diagram - Figure 8	14
Periodic Inspection	7	Valve Cross-Section - Figure 9	15
Maintenance	7	Part List	16
Actuator Casing Disassembly	7	Model Builder	20
Figure 4 - Wrench / Flat Detail	7		
Bonnet Removal	8		
Plug Removal	9		
Packing Removal	9		
Seat Ring Removal	9		



Model DF100 Control Valve

Operation, Parts, and Instruction Manual

NOTICE

These instructions are meant to be used with the Dyna-Flo DF100 Technical Bulletin as they refer to Figures and Tables therein. If you do not have the Technical Bulletin, contact Dyna-Flo immediately, or visit www.dynaflo.com

Each control valve is factory checked. Check the calibration for the specific application, before a valve is put into service.

It is the intention of this document to provide users with an accurate guide for safe installation and maintenance of the DF100 Control Valves. Revisions and updates are available at above mentioned website.

INTRODUCTION

The Model DF100 Series control valve is designed for throttle control and on/off control of a variety of fluids. These tough, compact valves are ideal for use in oil and gas separators, treaters, scrubbers or as dump valves. The DF100 is well suited for many other high pressure fluid applications up to 2250 psig (155 Bar). The DF100 Series control valve is available in 1 inch sizes in either a globe or tee style valve body with threaded end connections.

The Dyna-Flo DF100 Series control valve is manufactured to a high level of quality specifications to ensure superior performance and customer satisfaction.

GENERAL

The following instructions are to be thoroughly reviewed and understood prior to installing, operating or performing maintenance on this equipment. Work on this equipment should be performed by experienced personnel. Throughout the manual, safety and caution notes appear and must be strictly followed, to prevent serious injury or equipment malfunction.

SCOPE

The control valve configuration and construction materials were selected to meet particular pressure, temperature, and process fluid conditions. Some material combinations are limited in their pressure and temperature ranges. Do not apply any other conditions to the valve without first contacting your Dyna-Flo sales office.

This manual is written to be a practical and useful guide maintaining the Dyna-Flo DF100 Control Valve.

CAUTION

To avoid personal injury or installation damage as a result of the sudden release of process pressure or the breaking of parts, do not install the valve assembly where service conditions could exceed the limits stated in this manual or on the equipment nameplates. Use government codes, accepted industry standards and good piping practices to select pressure-relieving equipment for protection of your installation. It is also important to wear the proper protective equipment when performing any installation or maintenance activity.

Model DF100 Control Valve

Operation, Parts, and Instruction Manual



SPECIFICATIONS

Port Diameters

1/4", 3/8", 1/2", 3/4"

Valve Pressure Class / End Connection

- 1" FNPT ASME B16.34 Class 900

Maximum Pressure Drop

2,250 Psig (15,513 kPag)

Maximum Inlet Temperature and Pressures

2,250 Psig (15,513 kPag) from -46 to 93°C (-50 to 200°F)
2,185 Psig (15,513 kPag) at 149°C (300°F)

Standard Shut-off Classification

ANSI Class IV ANSI / FCI 70-2

Dimensions

See Figure 2

Flow Characteristics

Quick Opening

Flow Direction

Up or Down

- Flow Down recommended for Quick Open application
- Flow Up recommended for Throttling applications

Approximate Weight

20 lb (9 kg)

Maximum Travel

3/8 inch (10 mm)

Material Temperature Capabilities

Body Assembly

-46 to 149°C (-50 to 300°F)

Actuator Assembly

-40 to 82°C (-40 to 180°F)

Body Style

Available in Globe or Tee body style

Bonnet/Body Connection

Threaded

Actuator Configuration

The DF100 utilizes a on/off style spring and diaphragm actuator. Fail closed is field-reversible.

Maximum Actuator Casing Pressure

50 Psig (345 kPa)

Effective Actuator Diaphragm Area

33 inches² (213 cm²)

Actuator Pressure Connections

1/4 inch FNPT

For more information and other options contact your Dyna-Flo sales office.

Table 1

DF100 Sizing Coefficient Values

Body	Port Size Inch (mm)	C _V Value (100%)	X _T Value (100%)	F _L Value (100%)
Flow Up	1/4 (6.4)	1.7	0.67	0.92
	3/8 (9.5)	3.2	0.67	0.92
	1/2 (12.7)	4.8	0.67	0.92
	3/4 (19.1)	8.0	0.67	0.92
Flow Down	1/4 (6.4)	1.8	0.67	0.91
	3/8 (9.5)	3.7	0.67	0.91
	1/2 (12.7)	5.2	0.67	0.91
	3/4 (19.1)	8.32	0.67	0.91



Model DF100 Control Valve

Operation, Parts, and Instruction Manual

Table 2

Maximum Allowable Shutoff Pressure Drops

Actuator Action	Flow Direction (pressure tends to)	Port Diameter Inch	Number of Springs		Number of Springs	
			0 - 20 Psig Operating Signal		0 - 35 Psig Operating Signal	
			2	6	2	6
			Psi (kPa)	Psi (kPa)	Psi (kPa)	Psi (kPa)
Fail Closed	Flow Up (open valve)	1/4	1,578 (10,878)	2,250 (15,513)	1,578 (10,880)	2,250 (15,513)
		3/8	657 (4,530)	1,972 (13,596)	657 (4,530)	1,972 (13,596)
		1/2	341 (2,351)	1,025 (7,067)	341 (2,351)	1,025 (7,067)
		3/4	60 (414)	180 (1,241)	60 (414)	180 (1,241)
	Flow Down (close valve)	1/4	523 (3,606)	1,578 (10,880)	523 (3,606)	1,578 (10,880)
		3/8	837 (5,771)	2,250 (15,513)	837 (5,771)	2,250 (15,513)
		1/2	*	2,250 (15,513)	*	2,250 (15,513)
		3/4	*	1,603 (11,052)	*	2,250 (15,513)
Fail Open	Flow Up (open valve)	1/4	2,250 (15,513)	*	2,250 (15,513)	2,250 (15,513)
		3/8	2,250 (15,513)	*	2,250 (15,513)	2,250 (15,513)
		1/2	1,867 (12,873)	*	2,250 (15,513)	2,235 (15,410)
		3/4	759 (5,233)	*	1,882 / 130	834 (5,750)
	Flow Down (close valve)	1/4	2,250 (15,513)	*	2,250 (15,513)	2,250 (15,513)
		3/8	2,250 (15,513)	*	2,250 (15,513)	2,250 (15,513)
		1/2	2,250 (15,513)	*	2,250 (15,513)	2,250 (15,513)
		3/4	1,367 (9,425)	*	2,250 (15,513)	1,502 (10,356)

* - Valve will not shut off.

Model DF100 Control Valve

Operation, Parts, and Instruction Manual

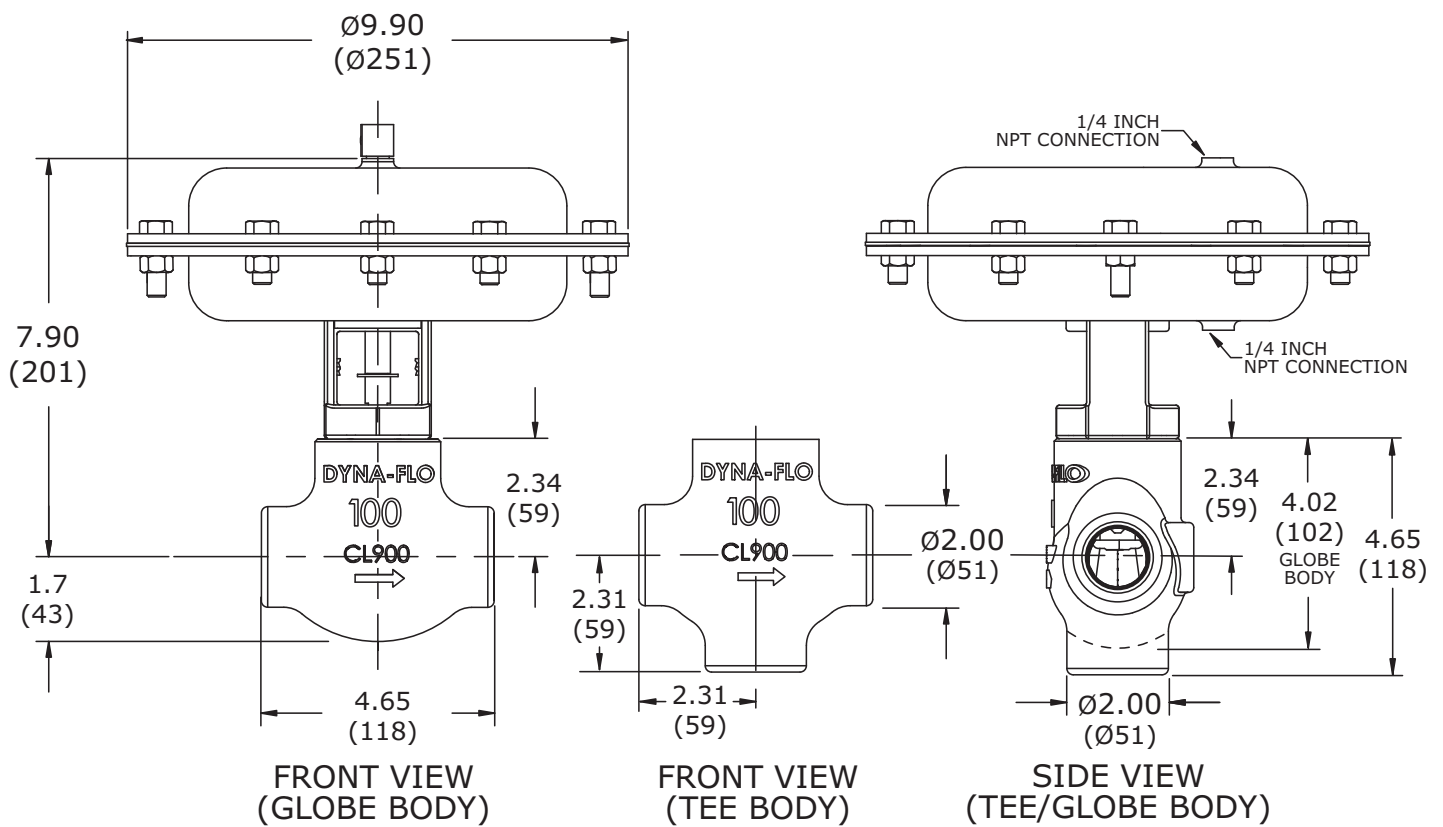

Figure 2 3 FNPT Style Valve Dimensions



Model DF100 Control Valve

Operation, Parts, and Instruction Manual

Table 3

DF100 RF and RTJ Valve Dimensions (Refer to Figure 3)
Inches (mm)

Connection	Class	A	B
RF	ASME 150	6.75 (171)	3.38 (86)
	ASME 300	7.25 (184)	3.63 (92)
	ASME 600	7.75 (197)	3.88 (99)
	ASME 900	8.63 (219)	4.32 (110)
RTJ	ASME 150	—	—
	ASME 300	7.63 (194)	3.82 (97)
	ASME 600	7.75 (197)	3.88 (99)
	ASME 900	8.63 (219)	4.32 (110)

NOTE: FNPT valves dimensions are available in Figure 3.

UNPACKING VALVE FROM SHIPPING CONTAINER

Check the packing list against materials received, while unpacking the valve. The Packing List describes valve and accessories in each shipping container.

When lifting the valve from shipping container, it is advisable to grasp the valve by the bonnet and body to remove from package. Use caution, the approximate weight of the valve is 20 lbs. (9 kg); the actuator assembly may make lifting and carrying the valve awkward.

INSTALLATION

Flow

The DF100 control valve is a bi-directional valve, although it is recommended that the DF100 be installed in flow up position. The arrow on the front of the valve body (Key 1) indicates recommended flow direction (flow up) (See Figure 9 on Page 15). Before installing the valve, clean dirt, welding chips, scale or other foreign material from the line. Look for signs of gasket leakage through the line flanges. Make repairs, if required.

WARNING

The DF100 control valve is sold standard in fail closed configuration. Do not tighten bonnet to body joint without first eliminating plug to seat contact! Tightening the bonnet / body joint with plug to seat contact will damage the seat and plug! Reference steps 1 of Bonnet Removal / Disassembly on Page 9.

Model DF100 Control Valve

Operation, Parts, and Instruction Manual



INSTALLATION (Continued)

- 1 When operating conditions allow, install the valve for the preferred flow direction. Refer to Table 2 for guide lines on shutoff pressure drops.

NOTE

The normal method of installation is with the actuator in vertical position above the valve body.

WARNING

Keep hands, hair and clothing away from all moving parts when operating the valve! Serious injury can result from failure to do so!

- 2 When possible, stroke the valve and check for smooth operation through the full-stroke. Unsteady valve stem movement could be an indication of an internal problem.

Air Piping

The actuators are designed to accept 1/4" NPT connection. Use 3/8" OD tubing (or equivalent) for all air lines. All connections must be free of leaks.

CAUTION

Do not exceed supply pressure indicated on serial plate located on the upper casing of the actuator.

Periodic Inspection

CAUTION

Use safe work practices and lock out procedures when isolating valves and actuators! Always be aware of flammable instrument gas!

- 1 Before performing any maintenance operation and to avoid injury from sudden release of process pressure:
 - A Use Safety lock-out procedures to be sure that the above provisions stay in effect while you complete the work on your equipment.
- 2 Check for process fluid leakage to the atmosphere through the body to bonnet joint and (if equipped) any NPT connection.
- 3 Examine the valve for damage caused by corrosive fumes or process drippings.

- 4 Clean the valve and repaint areas of severe oxidation.
- 5 Ensure all accessories, mounting brackets and fasteners are secure.

MAINTENANCE

Actuator Casing Disassembly

WARNING

When disassembling a Fail Closed DF100, it is necessary to retain the valve stem and plug in the slightly open position. This is done by inserting a 3/8" open end wrench as shown in Figure 4. Failure to retain the stem and plug will result in damage to the seating surfaces!

The following steps outline a Fail Closed actuator disassembly

- 1 If the machined flats of the valve stem are not visible through the bonnet window, it will be necessary to apply supply pressure to the valve in order to unseat the plug and expose the stem flats.
- 2 Insert a 3/8" open end wrench onto the machined flats of the valve stem (See Figure 4). Remove the supply pressure so that the wrench rests flat on the face of the bonnet (Key 2), keeping the valve stem (key 5) flats from retreating back into the bonnet and also keeping the plug (Key 4) from seating.



Figure 4 Wrench / Stem Flat Detail



Model DF100 Control Valve

Operation, Parts, and Instruction Manual

MAINTENANCE (Continued)

Actuator Casing Disassembly (Continued)

- 3 Vent the pneumatic actuator loading pressure. Make sure the 3/8" wrench is securely in place and keeping the valve stem from moving.

NOTE

The valve body can be serviced in-line (and without necessarily disassembling the actuator, refer to step 1 of Bonnet Removal / Disassembly on Page 9 for instructions). Release, or remove, all process pressure and fluid before servicing. If the valve is to be serviced out of line, it is important that the body (Key 1) be firmly held in a clamping device. Serious injury can result from failure to do so!

- 4 Begin by removing the 10 **short** (1") cap screws (Key 26) from the actuator casings (Key 15 & 24) using two 9/16" wrenches or an impact wrench with a 9/16" socket. Be sure to leave the 2 **long** cap screws.

CAUTION

The springs inside the actuator casings are still under compression. It is necessary to take proper safety precautions and to follow proper procedures.

- 5 Once the 10 **short** cap screws have been completely removed, begin loosening the two **long** (1-1/4") cap screws in an alternating pattern. During removal, try to keep the upper casing (Key 24) level until the springs are no longer under compression, then completely remove the long cap screws and upper casing.

NOTE

For a Fail Open actuator configuration, the actuator springs will not be immediately visible. The sequence of steps for disassembly of a Fail Open actuator are as follows: steps 7, 11, 10, 9, 8 & 6.

- 6 Remove the 6 actuator springs (Key 23) from the diaphragm plate (Key 20). To avoid plug and seat ring damage, be sure to manually pull the diaphragm plate up (for fail closed configuration) so the plug is off the seat ring. (See Maintenance WARNING on Page 7)
- 7 A 5/8" wrench is required to remove the travel stop (Key 22). Be sure to hold the 3/8" wrench (applied to the stem flats) with your other hand so that the stem does not rotate during travel stop removal.

- 8 Remove the diaphragm plate spacer (Key 21) and inspect the spacer for damage.
- 9 Remove the diaphragm plate (Key 20). Inspect the diaphragm plate for corrosion and damage.
- 10 Remove the diaphragm and inspect surface for wear, stretching and tears. Replace if necessary.
- 11 Remove the diaphragm plate washer (Key 18).

See steps 1-10 of Actuator Conversion for instructions on how to re-assemble the actuator for a Fail Open configuration.

- 12 To replace o-ring under lower casing use a 1-1/2" deep socket or wrench to remove the bonnet lock nut (Key 17).
- 13 Remove the flat washer (Key 16) and lower diaphragm casing (Key 15). Take note of the position of the lower casing for reassembly purposes.
- 14 Remove the casing o-ring (Key 13) and inspect for damage and disfigurement. Replace.

Bonnet Removal / Disassembly

WARNING

Before attempting to remove the bonnet take extreme caution to assure that process pressures have been removed and relieved. During the first full counter clockwise turn of the bonnet, the threads should begin to feel loose and the bonnet should rattle on the threads. If this does not occur, process pressure may still be present. Stop disassembly and investigate further. On Tee style bodies, a plug may be removed to assure drainage.

NOTE

To remove the bonnet (Key 2) from the valve body (Key 1), it is not necessary to disassemble the actuator or even remove the body from the line. Service the body only after all process pressure and fluid are released or removed. If the valve is to be serviced out of line, it is important that the body be firmly held in a clamping device. Serious injury can result from failure to do so!

Model DF100 Control Valve

Operation, Parts, and Instruction Manual



MAINTENANCE (Continued)

Bonnet Removal / Disassembly (Continued)

- 1 With the 3/8" wrench still applied to the valve stem flats, use another wrench and remove the bonnet from the body. (See Maintenance WARNING on Page 7)

Plug Removal

- 2 Hold the 3/8" wrench (applied to the stem flats) in one hand, apply a 5/8" open end wrench to the flats of the valve plug (Key 4) and remove the plug from the stem (Key 5). Inspect the plug and stem for thread damage, scratches or galling and replace plug if necessary. (See page 10 for Plug Installation steps)

Packing Removal

- 3 Place the bonnet in a clamping device and remove the bushing (Key 6) by sliding it off the valve stem (Key 5). Remove the bushing o-ring (Key 29) from the bushing and inspect the bushing for damage. Once the bushing (Key 6) is removed the disc springs (Key 8) may slide out, it may be easier to remove them at this point before removing the valve stem (Key 5) (Step 4).
- 4 Remove the travel indicator (Key 12). Remove the valve stem (Key 5) by sliding it out towards the diaphragm end of the bonnet, away from the packing retainer end. Replace any damaged parts.
- 5 Remove the disc springs if not already removed (Key 8), packing follower (Key 9), packing rings (Key 11). Inspect entire packing box content for damage, corrosion, deformation and replace if necessary.

Flip the Bonnet

- 5 Using a standard mechanic's "pick set" or a small flat head screwdriver, remove the stem o-ring (Key 14), try not to scratch or damage the bonnet walls. Inspect and replace o-ring if necessary.
- 6 Remove and inspect the stem bushing (Key 7), replace if necessary. For instructions on stem bushing insertion, see Bonnet Installation steps on page 11.

Seat Ring Removal

- 1 Remove the body o-ring (Key 29) and replace.
- 2 Using a 1-1/16" socket remove the valve seat ring (Key 3) from the body. Inspect the seat for galling, scratches, corrosion and thread damage. Replace seat if necessary.

- 3 Using a mechanic's "pick set" or small flat head screw driver, carefully remove the seat gasket (Key 28) from the body. Be careful not to scratch the seat surface.
- 4 Once the seat and gasket are removed from the body, thoroughly inspect the inside of the valve body for scratches, erosion, and damage. Replace body if necessary.

NOTE

If there may be a delay before valve re-assembly, it may be a good idea to cover the valve body.

REASSEMBLY

Bonnet Sub-assembly (Reference Figure 5)

- 1 With the bonnet (Key 2) sitting actuator side up, install the stem bushing (Key 7) through the bonnet window and up into the stem bore. Make sure that the "keeper lips" (ridge) of the bushing is inserted up into the bonnet. It may be necessary to depress the "tabs" of the bushing in order to insert it. Push the bushing into the bonnet until the bushing "snaps" into place.
 - 2 Lubricate the stem o-ring (Key 14) with o-ring lubricant and install the o-ring into the o-ring groove in the top of the bonnet. Use a flat head screwdriver to help work the o-ring carefully into the groove so as not to cut the o-ring or damage the bonnet.
- #### Flip the bonnet
- 3 Lubricate the packing rings (Key 11) and install the packing rings into the packing bore as per Figure 5. Make sure the rings touch the spacer.
 - 4 Install the packing follower (Key 9) over the packing rings with the flat face towards the packing rings.
 - 5 Install the 4 disc springs (Key 8), see Figure 5 for the order of installation.
 - 6 Lubricate the bushing o-ring (Key 29) and slide it onto the bushing (Key 6) as shown in Figure 5. Insert the bushing with the bushing o-ring facing the Belleville washers (Key 8) into the bonnet (Key 2) so that the bushing (Key 6) has an approximate 0.80" gap between it and the bonnet (Key 2). See Figure 5 for detail.
 - 7 Install the bushing washer (Key 32) on to the bushing seat inside of the valve body. See Figure 5 and 9 for detail.

Flip the bonnet



Model DF100 Control Valve

Operation, Parts, and Instruction Manual

REASSEMBLY (Continued)

Stem Installation (Continued)

- 8 It is important to insert the valve stem (Key 5) into the bonnet starting from the actuator end (opposite from the packing retainer) with the plug threads first. Be careful when inserting the stem so that the stem flats do not damage the stem o-ring. The plug end on the valve stem should protrude slightly past the bushing so that the stem flats are still visible in the bonnet window. Align the stem flats to run parallel to the bonnet window.

Valve Plug Installation

- 9 Apply medium strength liquid thread locker to the threads of the valve plug (Key 4).
- 10 Apply a 3/8" open end wrench to the machined stem flats. Thread the plug (Key 4) and using a 5/8" wrench (applied to the flats of the plug) fully tighten the plug into the stem (approximately 24 lbf-ft). **NOTE:** To avoid damage, it may be necessary to manually pull up on the valve stem until the valve plug makes contact with the bushing (Key 6) during bonnet installation. Packing box parts are loose inside until bonnet is tightened.

Seat Ring Installation

With the body secured in a clamping device (do not over tighten device on valve body)

- 1 Clean and inspect the inside of the valve body (Key 1), make sure there is no debris or damage. Coat both sides of the seat ring gasket (Key 28) with nickel based anti-seize compound. Place the seat ring gasket inside the body, use a small flat head screwdriver to help carefully align the gasket to be concentric with the bore.
- 2 Apply the nickel based anti-seize compound to the threads of the seat ring (Key 3). Carefully place the seat ring inside the body (hex head up) and thread the seat ring into the body. Torque seat ring to 150 lbf-ft.

NOTE

Any significant resistance to seat ring installation should be investigated. Dry threads could prevent proper seating of the seat ring against the gasket, allowing leakage.

- 3 Lubricate the body o-ring (Key 30) with o-ring lubricant. Install the o-ring on the top gasket face of the body.

- 4 Lubricate the internal threads of the body with nickel based anti-seize compound.

Bonnet Installation

NOTE

It is important to make sure that the valve plug will not make contact with the seat ring during bonnet installation. Apply a 3/8" wrench to the stem flats if necessary. (See NOTE in Step 10 of Valve Plug Installation on Page 10)

- 5 Thread the bonnet sub-assembly into the body until hand tight. Use a wrench to tighten the bonnet into the body approximately 300 lbf-ft. (Make sure the bushing washer (Key 32) is properly seated on the bushing seat inside the valve body. See Step 7, page 10.)
- 6 Lubricate the casing o-ring (Key 13) with o-ring lubricant and insert it into the top o-ring groove of the bonnet.

Actuator Reassembly (Fail Closed)

WARNING

When disassembling a Fail Closed DF100, it is necessary to retain the valve stem and plug in the slightly open position. This is done by inserting a 3/8" open end wrench as shown in Figure 4. Failure to retain the stem and plug will result in damage to the seating surfaces!

- 1 If maintenance has occurred and the valve has been disassembled, after the bonnet has been installed into the valve body leave the body in the clamping device.
- 2 Place the lower diaphragm casing (Key 15) over the valve stem so that it rests on the casing o-ring (Key 13). Orientate the NPT connection of the casing so that it is centered within the bonnet window (Key 2). Reference Figures 2 and 9 for correct NPT orientation.
- 3 Install the flat washer (Key 16) over the valve stem so that it rests on the lower casing.
- 4 Apply nickel based anti-seize compound to the exposed bonnet threads.
- 5 While holding the lower casing in place, thread the bonnet locknut (Key 17) onto the bonnet using a 1-1/2" deep socket tighten to 200 lbf-ft.

Model DF100 Control Valve

Operation, Parts, and Instruction Manual



- 6 Install the diaphragm plate washer (Key 18) over the valve stem (Key 5).
- 7 Place the diaphragm (Key 19) over the stem so that it is in contact with the diaphragm plate washer. Be sure to align the holes of the diaphragm with the bolt holes on the lower casing (Key 15).
- 8 Slide the diaphragm plate (Key 20) over the stem so that it rests with the flat face against the diaphragm. Reference Figure 8 for correct diaphragm plate placement.
- 9 Install the diaphragm plate spacer (Key 21) over the stem so that it rests on top of the diaphragm plate.
- 10 Apply medium strength liquid thread locker to the threads of the travel stop (Key 22) and thread it onto the valve stem. **Be sure to hold the 3/8" wrench applied to the stem flats to keep the stem from rotating while tightening the travel stop.** Using a 5/8" socket, torque down the travel stop to 100 lbf-in.
- 11 Place the springs (Key 23) on the diaphragm plate in a circular pattern, with each spring centered on the plate protrusions.

NOTE _____
A conversion from fail open to fail closed (or vice versa) may not be possible without 4 extra springs (dependant on shutoff pressure needed see Table 2).

- 12 Place the upper casing (Key 24) over the springs, be sure that the NPT connection of the upper casing is aligned with the NPT connection of the lower casing. Also, be sure that the bolt holes of the upper casing are aligned with the bolt holes of the lower casing.
- 13 Install both of the **long** (1-1/4") cap screws (Key 25) opposite from each other and in line with the valve body. Partially thread a nut (Key 27) onto one of the **long** cap screws.
- 14 It may be necessary to compress the springs by pushing slightly on the upper casing to thread a nut onto the second **long** cap screw. Using two 9/16" wrenches or socket set, tighten the two **long** cap screws using an alternating pattern. Until the 10 **short** cap screws can be installed and the nuts threaded on. Try to keep the upper diaphragm casing level during this process.

- 15 Completely tighten the 12 nuts.
- 16 Install the vent cap (Key 31) to the NPT connection on the upper casing.
- 17 It will be necessary to apply supply pressure to the actuator in order to remove the 3/8" wrench on the stem flats.

ACTUATOR CONVERSION

Fail Open Assembly

NOTE _____
If actuator conversion is all that is required and o-ring and bonnet maintenance is unnecessary, complete disassembly of the lower casing will not be required. Follow steps 1-11 of actuator disassembly on page 6. Actuator assembly and maintenance should only be performed by trained individuals adhering to proper procedures and safety precautions.

Reference Figure 6 on Page 13 for diagram.

NOTE _____
A conversion from fail open to fail closed (or vice versa) may not be possible without 4 extra springs (dependant on shutoff pressure needed see Table 2).

- 1 If the actuator has not yet been disassembled, refer to Actuator Casing Disassembly on Page 7. It may be unnecessary to disassemble the actuator passed step 11.
- 2 Install the diaphragm plate spacer (Key 22) over the stem.
- 3 Set the required springs (Key 24) onto the inside of the lower casing, spacing them equally in a circular pattern. Position the springs so that they will line up with the raised bumps of the diaphragm plate (Key 21).
- 4 Place the diaphragm plate over the valve stem so that the concave face touches the springs and the protrusion locates inside the spring.
- 5 Place the diaphragm (Key 20) over the stem so that it is in contact with the diaphragm plate. Make sure the holes on the diaphragm are aligned with the bolt holes on the casing.
- 6 Install the diaphragm plate washer (Key 19) over the valve stem so that it rests on top of the diaphragm.



Model DF100 Control Valve

Operation, Parts, and Instruction Manual

ACTUATOR CONVERSION (Continued)

Fail Open Assembly (Continued)

- 7 Apply medium strength liquid thread locker to the threads of the travel stop (Key 22) and thread it onto the stem.
- 8 Apply a 3/8" wrench to the machined flats of the valve stem (Key 5) to prevent stem movement during travel stop installation. Using a 5/8" socket, torque down the travel stop to 100 lbf-in.

- 9 Install the two **long** (1-1/4") cap screws (Key 26) opposite each other making sure they are in line with the valve body (this is to prevent future complications). Install the 10 **short** (1") cap screws (Key 27) and thread a nut (Key 28) onto all 12 cap screws. Using two 9/16" wrenches or socket set, completely tighten all the nuts and cap screws.
- 10 Install the vent cap (Key 31) to the NPT connection on the lower casing. Remove the 3/8" wrench from the stem flats.

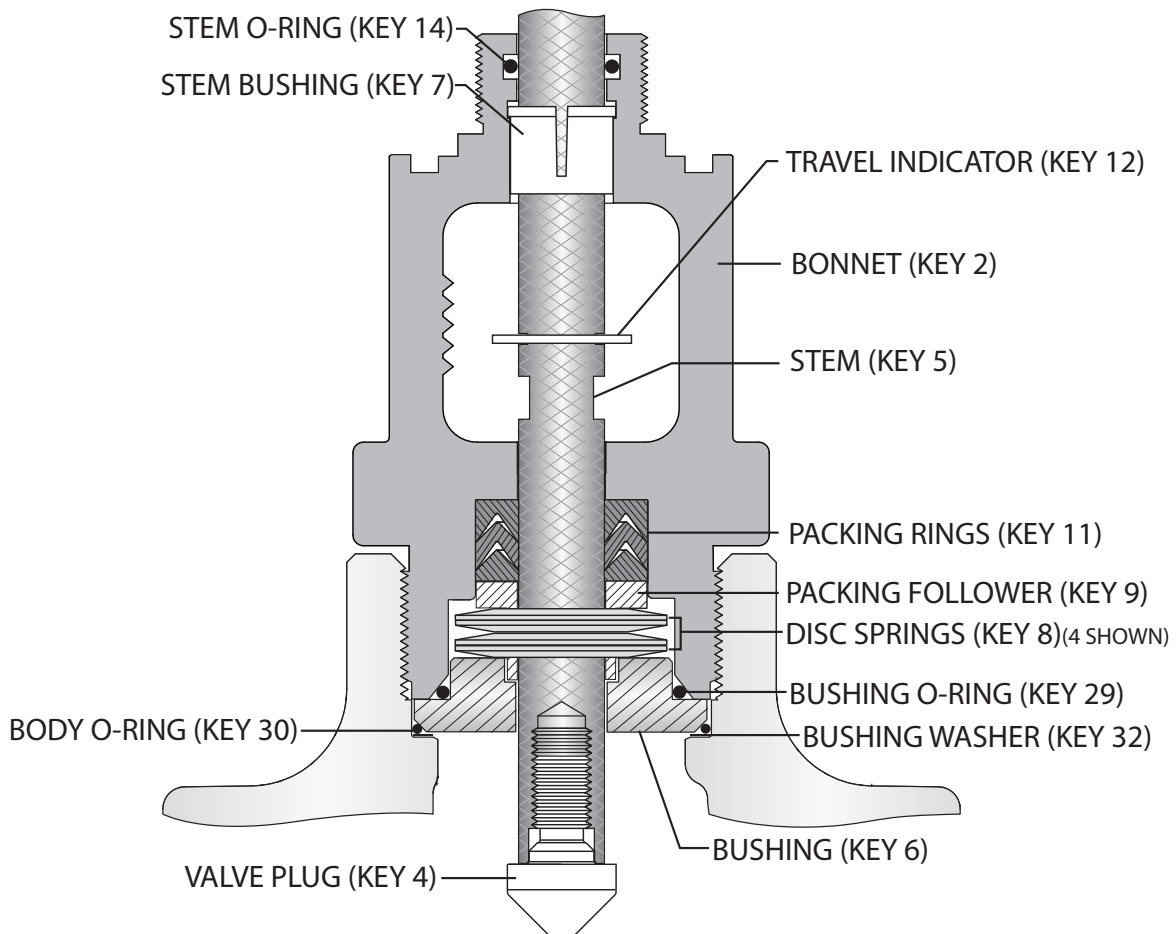

Figure 5 Packing Installation Diagram

Model DF100 Control Valve

Operation, Parts, and Instruction Manual

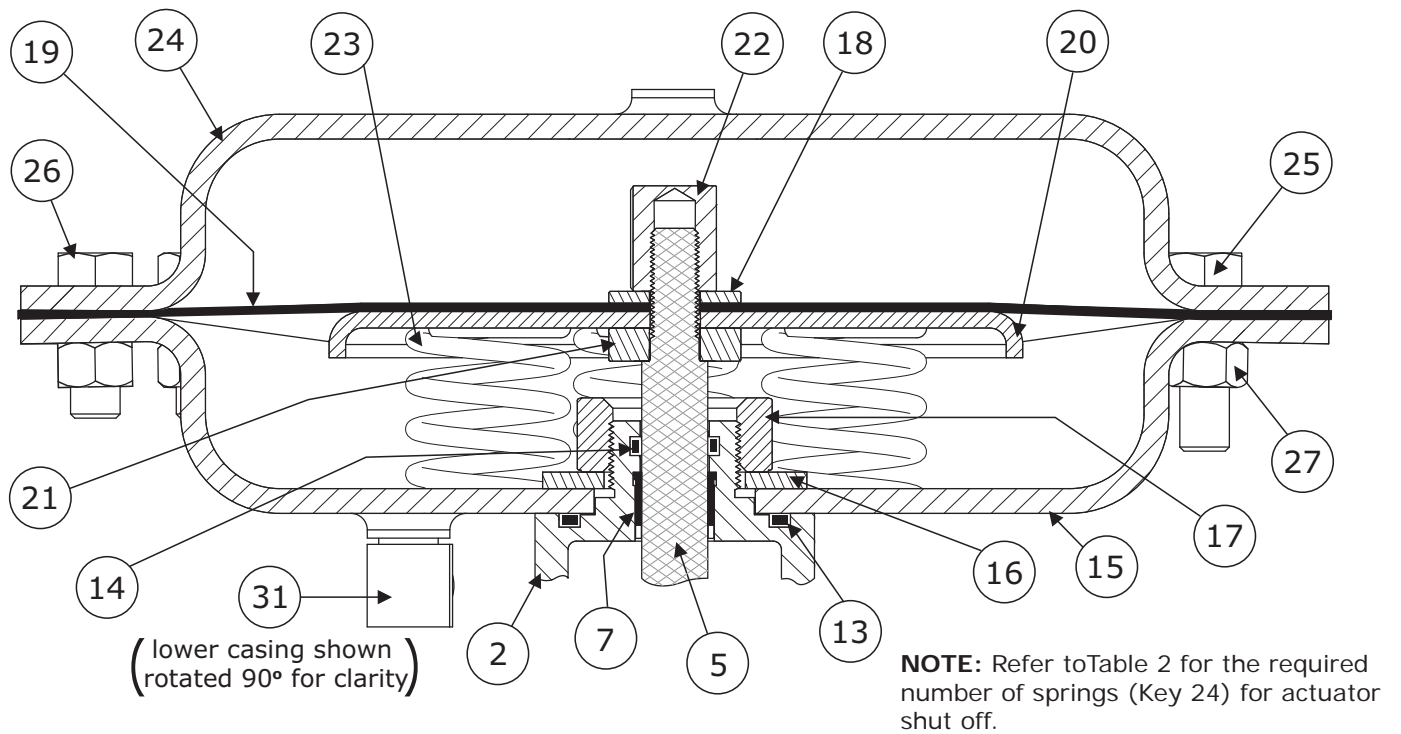

Figure 6 Fail Open Cross Section

Model DF100 Control Valve

Operation, Parts, and Instruction Manual

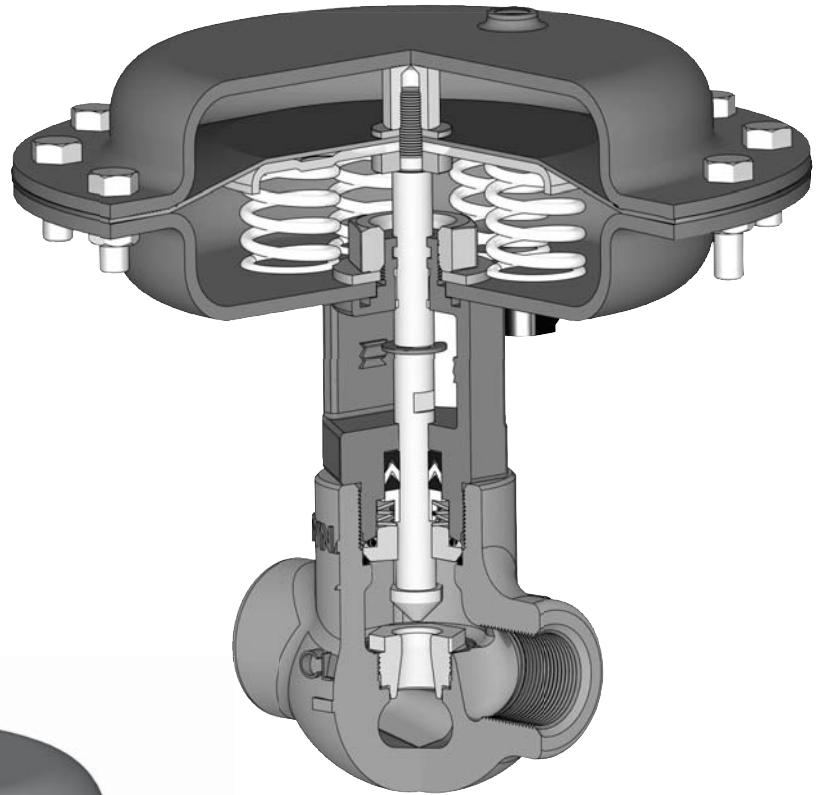

Figure 7
*Fail Open Globe Body
Cross Section*

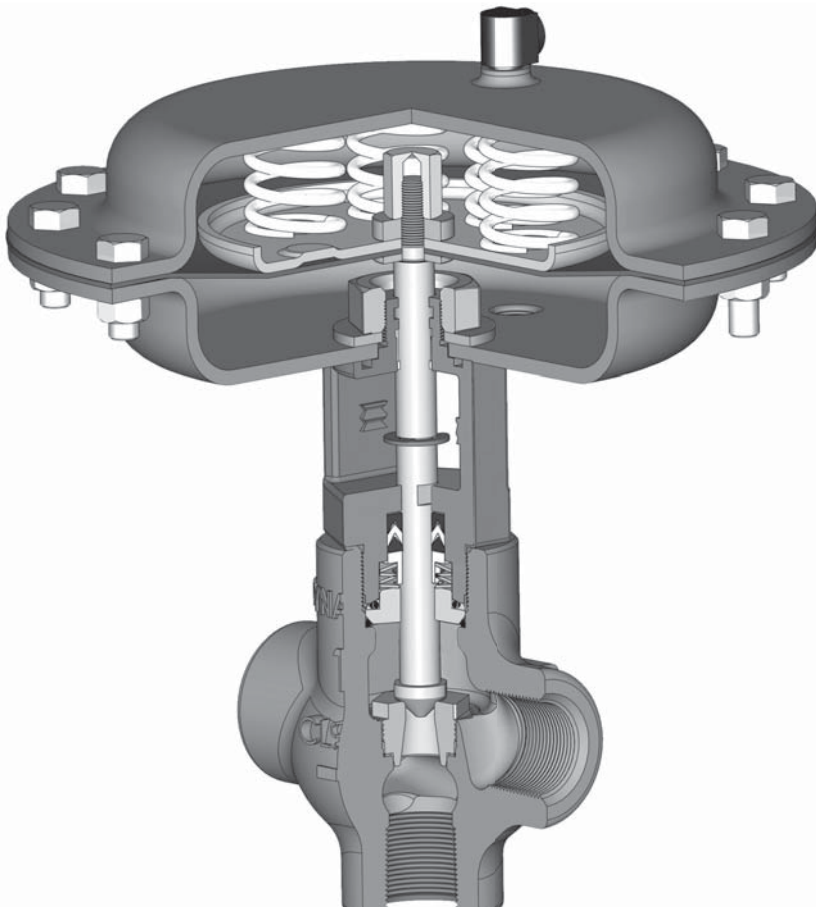

Figure 8
*Fail Closed Tee Body
Cross Section*

Model DF100 Control Valve

Operation, Parts, and Instruction Manual

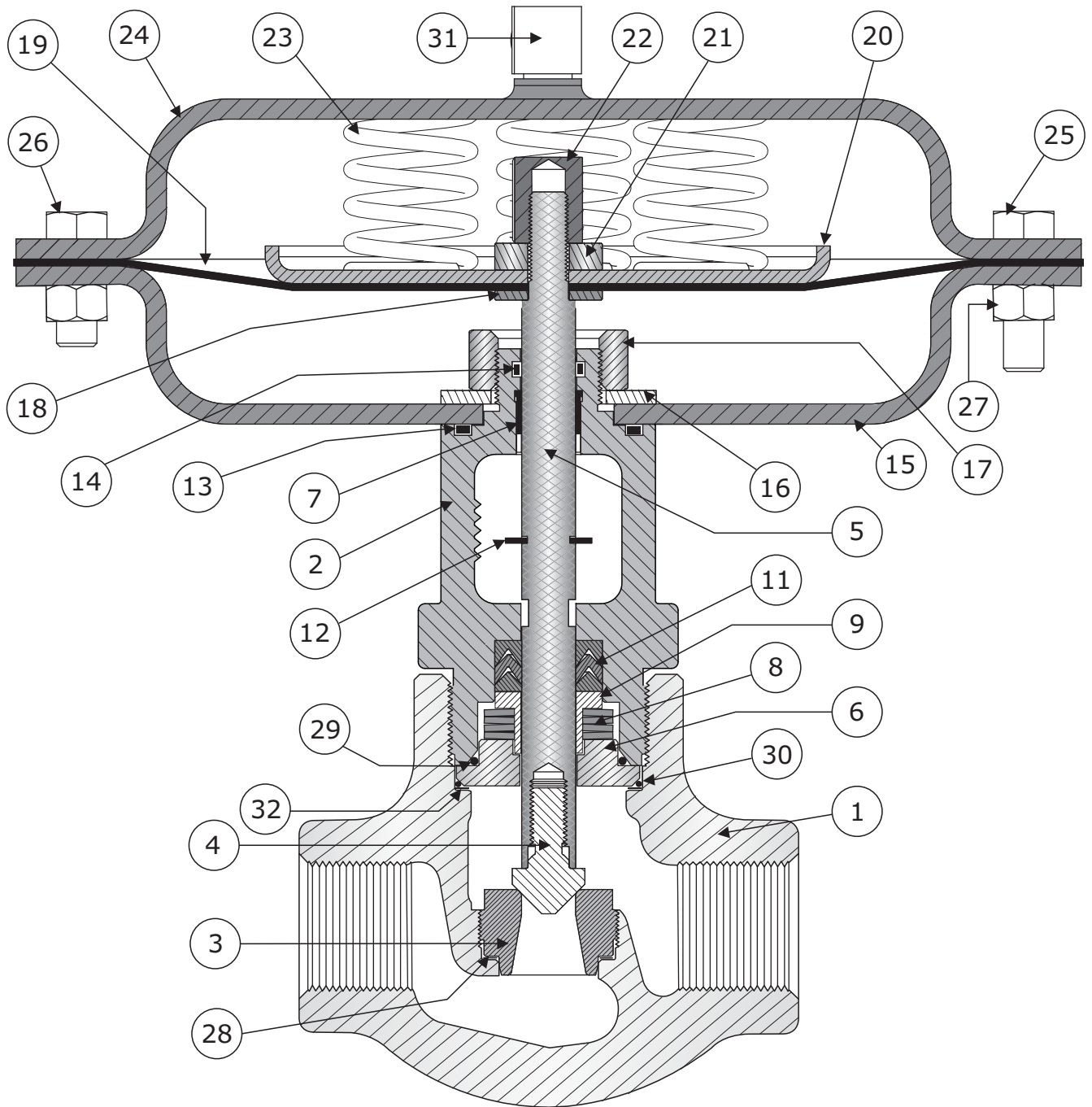

Figure 9 Fail Closed Cross Section FNPT



Model DF100 Control Valve

Operation, Parts, and Instruction Manual

PARTS LIST

Key	Description	Material	Part Number
1	Body	LCC	
	Globe		DF10301X01D
	Tee		DF10307X01D
2	Bonnet	LCC	DF10201X21D
3	Seat Ring		
	1/4 Inch Port	S17400 DH1150	DF10514X01D
	3/8 Inch Port	S17400 DH1150	DF10538X01D
	1/2 Inch Port	S17400 DH1150	DF10512X01D
	3/4 Inch Port	S17400 DH1150	DF10534X01D
	1/4 Inch Port	S17400 DH1150 Tungsten Carbide	DF10514X07D
	3/8 Inch Port	S17400 DH1150 Tungsten Carbide	DF10538X07D
	1/2 Inch Port	S17400 DH1150 Tungsten Carbide	DF10512X07D
4	Valve Plug		
	1/4 — 1/2 Inch (1/4 & 3/8 Inch Port)	S17400 DH1150	DF10501X01D
	3/4 Inch	S17400 DH1150	DF10502X01D
	1/4 — 1/2 Inch (1/4 & 3/8 Inch Port)	S17400 DH1150 Tungsten Carbide	DF10502X07D
	3/4 Inch	S17400 DH1150 Tungsten Carbide	DF10502X07D
5	Valve Stem	S31600/S31603 Dual Grade	DF10302X01D
6	Bushing	S17400 DH1150	DF10216X11D
7	Stem Bushing	Ryton (PPS)	DF10205X01D
8	Disc Springs (4 Required)	N07718	Part of Spring Pack
9	Packing Follower	S31600	Part of Spring Pack
11	Packing Rings	PTFE / Carbon PTFE	DF10206X01D
12	Travel Indicator	Zinc Plated Steel	DF20221X01D
13	Casing O-Ring	Hydrogenated Nitrile (HNBR)	DF10209X01D
14	Stem O-Ring	Hydrogenated Nitrile (HNBR)	DF10210X01D
15	Lower Casing	44W	DF10401X01D
16	Flat Washer	Zinc Plated Steel	FWZN100
17	Bonnet Locknut	Zinc Plated Steel	DF10208X01D
18	Diaphragm Plate Washer	S30300	DF10405X01D
19	Diaphragm	Nitrile / Polyester	DF10404X01D
20	Diaphragm Plate	Steel	DF10403X02D
21	Diaphragm Plate Spacer	S30300	DF10406X01D
22	Travel Stop	Zinc Plated Steel	DF10211X01D
23	Spring (Max. 6 Req'd)	Zinc Plated Steel	DF10407X01D
24	Upper Casing	44W	DF10408X01D
25	Long Cap Screw (2 Required)	Zinc Plated Steel	H5FZ38.114
26	Short Cap Screw (10 Required)	Zinc Plated Steel	H5FZ38.100
27	Nut (12 Required)	Zinc Plated Steel	NHFZ38

Model DF100 Control Valve

Operation, Parts, and Instruction Manual



PARTS LIST

Key	Description	Material	Part Number
27	Nut (12 Required)	Zinc Plated Steel	NHFZ38
28	Seat Ring Gasket	S30400	DF10306X01D
29	Bushing O-Ring	Hydrogenated Nitrile (HNBR)	DF10217X11D
30	Body O-Ring	Hydrogenated Nitrile (HNBR)	DF10218X01D
31	Vent Cap	Plastic	Y602-12D
32	Bushing Washer	S30400	DF10220X01D
	Spring Pack Assembly (Keys 8 & 9)	S31600 / N07718	DF10219X01D

DF100 Parts Kits

Description	Part Number
-------------	-------------

DF100 Trim Kit (S17400 DH1150 Plug / Seat Ring)⁽¹⁾

1/4 Inch Trim Size	RDF1014X01D
3/8 Inch Trim Size	RDF1038X01D
1/2 Inch Trim Size	RDF1012X01D
3/4 Inch Trim Size	RDF1034X01D

DF100 Trim Kit (S17400 DH1150 Tungsten Carbide Plug / Seat Ring)⁽¹⁾

1/4 Inch Trim Size	RDF1014X07D
3/8 Inch Trim Size	RDF1038X07D
1/2 Inch Trim Size	RDF1012X07D
3/4 Inch Trim Size	RDF1034X07D

Valve Repair Kit (Packing Set, Stem Bushing, Stem O-Ring, Casing O-ring, Body O-Ring, Bonnet O-Ring, Seat Ring Gasket, Bushing Washer)	RDF100X001D
---	-------------

NOTE:

1 - Includes Seat Gasket, Bonnet O-Ring, Body O-ring, Bushing Washer.

PARTS ORDERING

Whenever corresponding with Dyna-Flo about a DF100 Control Valve, refer to the nameplate for the serial number of the unit. Please order by the complete part number (as given in the following parts list) of each part required.

Model DF100 Control Valve

Operation, Parts, and Instruction Manual



Our Commitment to Quality

Dyna-Flo is committed to continuous improvement. While all efforts have been made to ensure the accuracy of the content in this document, modifications or improvements to the information, specifications, and designs may occur at any time without notice. This document was published for informational purposes only, and does not express or imply suitability, a warranty, or guarantee regarding the products or services described herein or their use or applicability.

Neither Dyna-Flo Control Valve Services Ltd., nor any of their affiliated entities assumes responsibility for the selection, use and maintenance of any product. Responsibility for selection, use and maintenance of any product remains with the purchaser and end-user.

Model DF100 Control Valve

Operation, Parts, and Instruction Manual



This page left intentionally blank.



Model DF100 Control Valve

MODEL NUMBERING SYSTEM

SAMPLE PART NUMBER: DF100-GC3-6BF-14S

BODY STYLE				G
G	GLOBE STYLE	T	TEE STYLE	
ACTUATOR STYLE				C
C	FAIL CLOSED	O	FAIL OPENED	
SPRING RANGE				3
3	SIZE 25 ACTUATOR WITH 3 - 15 SPRING	6	SIZE 25 ACTUATOR WITH 6 - 30 SPRING	
NUMBER OF SPRINGS				6
2	2 SPRINGS	6	6 SPRINGS	
ASME RATING				B
A	ASME CLASS 150	B	ASME CLASS 300	
C	ASME CLASS 600	D	ASME CLASS 900 (STANDARD FOR NPT)	
CONNECTION STYLE				F
N	NPT (NATIONAL PIPE THREAD)			
TRIM SIZE				14
14	1/4 INCH	38	3/8 INCH	
12	1/2 INCH	34	3/4 INCH	
TRIM MATERIAL				S
S	S17400 DH1150	T	TUNGSTEN CARBIDE	

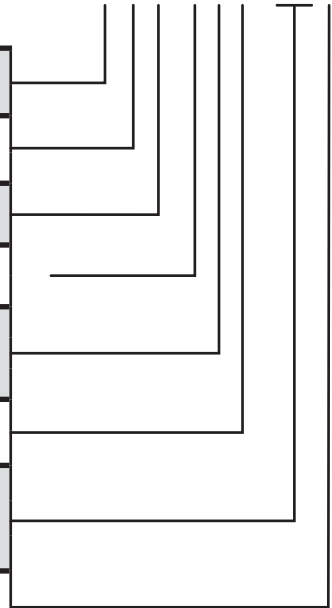

DF100 - - - - -