

Series 1890

Pressure Relief Valves for Air,
Steam, Vapor & Liquid Service

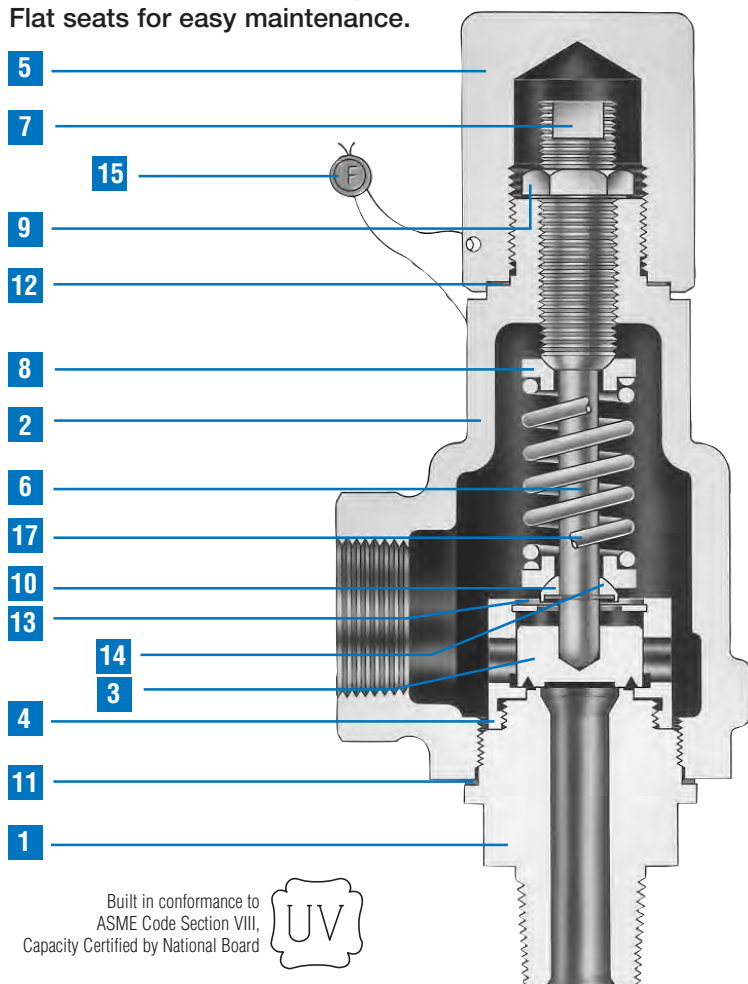

- Built in conformance to ASME Code Section VIII for Air, Steam, and Liquid Service.
- Set pressures to 800 psig.
- Stainless steel body and trim.
- Carbon steel bonnet and cap.
- Flat seats for easy maintenance.



Built in conformance to ASME Code Section VIII, Capacity Certified by National Board



Bill of Materials

Item No.	Part Name	Material 1890 & 1892
1	Body	SA-479 Type 316 St. St.
2	Bonnet	SA-216 Gr. WCB Carbon Steel
3	Disc	316 St. St.
4	Guide	Stainless Steel
5	Cap, Plain Screwed	Carbon Steel
6	Stem	Stainless Steel
7	Spring Adj. Screw	Stainless Steel
8	Spring Button	Stainless Steel
9	Jam Nut	Stainless Steel
10	Stem Shoulder	Stainless Steel
11	Body Gasket	316 St. St.
12	Cap Gasket	316 St. St.
13	Lift Stop Ring	Stainless Steel
14	Retaining Ring-Stem Shoulder	Stainless Steel
15	Wire Seal	Lead
16	Nameplate (not shown)	Stainless Steel
17	Spring	See Selection Table

General Notes:

1. Test lever required for air, steam, and hot water (above 140°F) service. For packed lever, add PKD. Example: 1892-PKD. For test gag, add W/TG.

Selection Table

Type Number	Valve Size Inlet x Outlet	Connections		Maximum Set Pressure, psig		Maximum Set Pressure, Bar G		Maximum Back Pressure		Materials	
		Inlet	Outlet	-20°F to +400°F	+400°F to +750°F	-28.9°C to +204°C	+205°C to +399°C	Pressure		Body/Bonnet	Spring
								psig	Bar G		
1890	1/2 x 1 & 3/4 x 1	Male NPT	Female NPT	800	—	55	—	50	3.45	316 St. St./ Carbon Steel	316 St. St.
1892	1/2 x 1 & 3/4 x 1	Male NPT	Female NPT	—	800	—	55	50	3.45	316 St. St./ Carbon Steel	Chrome Alloy Rust Proofed



Farris Engineering

Division of Curtiss-Wright Flow Control Corporation





Capacity Tables: ASME PRESSURE VESSEL CODE (UV)

AIR 10% OVERPRESSURE Capacities in Standard Cubic Feet Per Minute at 60° F	
Set Pressure (psig)	Air Capacity
15	51
20	59
30	74
40	91
50	108
60	125
70	143
80	160
90	177
100	194
120	228
140	262
160	296
180	331
200	365
220	399
240	433
260	468
280	502
300	536
320	570
340	604
360	639
380	673
400	707
420	741
440	775
460	810
480	844
500	878
600	1049
700	1220
800	1391

STEAM 10% OVERPRESSURE Capacities in Lbs. Per Hour at Saturation Temperature	
Set Pressure (psig)	Steam Capacity
15	143
20	165
30	208
40	256
50	304
60	353
70	401
80	449
90	497
100	545
120	641
140	737
160	833
180	929
200	1025
220	1121
240	1217
260	1313
280	1410
300	1506
320	1602
340	1698
360	1794
380	1890
400	1986
420	2082
440	2178
460	2274
480	2371
500	2467
600	2947
700	3428
800	3908

WATER 10% OVERPRESSURE Capacities in U.S. Gallons Per Minute at 70° F (See Note 2)	
Set Pressure (psig)	Water Capacity
15	9.4
20	10.6
30	12.7
40	14.7
50	16.4
60	17.9
70	19.4
80	20.7
90	22.0
100	23.2
120	25.4
140	27.4
160	29.3
180	31.1
200	32.8
220	34.4
240	35.9
260	37.4
280	38.8
300	40.1
320	41.4
340	42.7
360	44.0
380	45.2
400	46.3
420	47.5
440	48.6
460	49.7
480	50.8
500	51.8
600	56.8
700	61.3
800	65.5

Notes: 1. Capacities at 30 psig and below are based on 3 psi overpressure. 2. To determine water capacity at 25% overpressure, multiply the capacity at 10% by 1.066.

Effective Orifice Areas				
Inlet Size	Liquids		Air, Gas & Steam	
	Sq. In.	Sq. mm	Sq In.	Sq. mm
1/2" or 3/4"	0.077	49.68	0.089	57.42

Notes: 1. For sizing purposes, the coefficient of discharge K_d is 0.953 for air, gas and vapor.
2. For liquid service, use the ASME liquid equation with a coefficient of discharge K_d equal to 0.755.

Dimensions & Weights						
Type Number	A		B	C	Approx. Weight Lbs/Kgs	
	Plain Cap	Packed Lever				
1890	In.	6 11/16	8	1 11/16	2 5/8	3 1/2
	mm	170	203	43	67	1.6

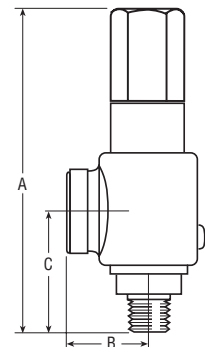

Farris Engineering

Division of Curtiss-Wright Flow Control Corporation

10195 Brecksville Road, Brecksville, OH 44141 USA • Telephone: 440/838-7690 • Fax: 440/838-7699 • www.cwfc.com

Facilities: Brecksville, OH USA, E. Farmingdale NY USA, Brantford, Ontario, Bridport, Dorset, UK

Offices: worldwide. For a listing of our global sales network, visit our website at www.cwfc.com.

While this information is presented in good faith and believed to be accurate, Curtiss-Wright Flow Control Corporation, Farris Engineering, does not guarantee satisfactory results from reliance on such information. Nothing contained herein is to be construed as a warranty or guarantee, expressed or implied, regarding the performance, merchantability, fitness or any other matter with respect to the products, nor as a recommendation to use any product or process in conflict with any patent. Curtiss-Wright Flow Control Corporation, Farris Engineering, reserves the right, without notice, to alter or improve the designs or specifications of the products described herein.