



# Series 6400/6600

Safety Valves for Power Boiler Service



**Farris Engineering**

*Division of Curtiss-Wright Flow Control Corporation*



Designed with the user in mind, Series 6400 and 6600 safety valves represent the most advanced technology in valves designed for use in intermediate power boiler and organic fluid vaporizer service. Built in conformance to Section I of the ASME Boiler and Pressure Vessel Code, all capacities are certified by The National Board of Boiler and Pressure Vessel Inspectors at 3% overpressure.

## Outstanding features include:

- Full nozzle design for minimized maintenance
- Hardened conical disc for extended seat life
- Monel® or copper nickel alloy guides with long guiding ratio for reduced galling used on high temperature models
- Set pressure to 1500 psig, temperatures to 1000° F
- Available in closed bonnet or exposed spring versions
- Dual blow down ring for more precise performance

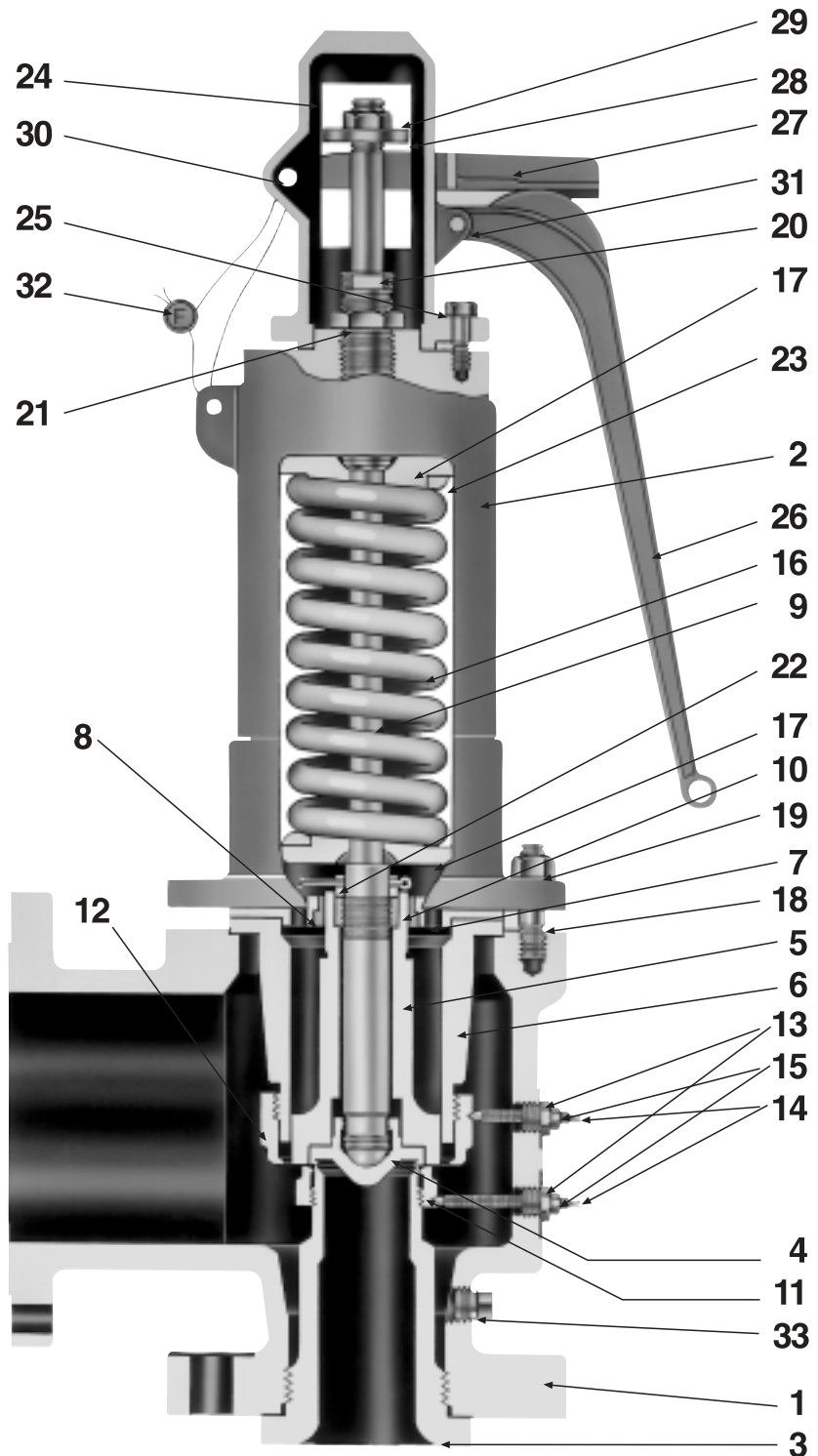

Built in conformance to  
ASME Code Sections I and VIII  
for Steam Service



# Series 6400/6600 Bill of Materials

Item No.	Part Name	Material
1	Body (up to 800° F) Body (801° F to 1000° F)	SA-216 GR. WCB Carbon Steel SA-217 GR. WC6 Alloy Steel (1 1/4 CR - 1/2 Moly)
2	Open Bonnet / Yoke (6400 Series) Closed Bonnet (6600 Series)	SA-216 GR. WCB Carbon Steel SA-216 GR. WCB Carbon Steel
3	Nozzle	316 St. St.
4	Disc	Precipitation Hardened St. St.
5	Disc Holder	Precipitation Hardened St. St.
6	Sleeve Guide (Up to 800° F)	300 Series Stainless Steel
	Sleeve Guide (801° F to 1000° F)	Monel
7	Guide Plate (note 1)	300 Series Stainless Steel
8	Guide Bushing (note 1)	Monel
9	Stem	316 Stainless Steel
10	Stem Collar	316 Stainless Steel
11	Blow Down Ring-Lower	316 Stainless Steel
12	Blow Down Ring-Upper	316 Stainless Steel
13	Lock Screw (Blow Down Ring)	316 Stainless Steel
14	Lock Screw Stud (BDR)	316 Stainless Steel
15	Jam Nut, Lock Screw	Stainless Steel
16	Spring (Up to to 1000° F) (note 2)	Chrome Alloy, Rust Proofed
17	Spring Buttons	Carbon Steel, Rust Proofed or 316 St.St.
18	Body Stud	ASTM A193 Gr. B7 Alloy Steel
19	Hex Nut, Body	ASTM A194 GR. 2H Alloy Steel
20	Spring Adjusting Screw	Precipitation Hardened St. St.
21	Spring Adj. Scr. Jam Nut	316 Stainless Steel
22	Cotter Pin	Steel, Pltd.
23	Spring Pin	Carbon Steel, Pltd.
24	Cap (6400 Series)	Iron
	Cap (6600 Series)	Steel
25	Cap Screw	Carbon Steel, Pltd.
26	Test Lever	Iron
27	Test Lever Fork	Iron
28	Stem Test Nut	316 Stainless Steel
29	Jam Nut, Stem	Stainless Steel
30	Round Head Rivet (Fork)	Steel
31	Round Head Rivet (Lever)	Steel
32	Wire Seal	St. St. Wire / Lead Seal
33	Pipe Plug, Body	Steel
34	Nameplate (Not Shown)	Stainless Steel

### General Notes:

1. Guide plate and Guide bushing form a one piece assembly.  
Used on 2-1/2" to 4" inlet sizes only. No Bushing is used on valves up to 800° F.
2. Closed Bonnet Series 6600 uses a high temperature alloy steel spring for temperatures above 800° F.
3. Gaskets are used on Series 6600 Closed Bonnet units only.  
Material is stainless steel.

# Selection Table: Series 6400, Open Bonnet



Orifice		Valve Size Inlet x Outlet	ANSI Flange Class		Type Number	Max. Set Press. PSIG at 650°F	Type Number	Max. Set Press. PSIG at 800°F	Type Number	Max. Set Press. PSIG at	
Letter	Area Sq. In.		Inlet	Outlet RF						950°F	1000°F
D	0.150	1 X 2	300#	150#	64DA12-170	300	64DA22-170	300	64DA32-170	300	225
			600#		64DA13-170	600	64DA23-170	600	64DA33-170	600	445
			900#		64DA14-170	900	64DA24-170	900	64DA34-170	900	670
			1500#		64DA15-170	1500	64DA25-170	1500	64DA35-170	1500	1115
E	0.225	1 X 2	300#	150#	64EA12-170	300	64EA22-170	300	64EA32-170	300	225
			600#		64EA13-170	600	64EA23-170	600	64EA33-170	600	445
			900#		64EA14-170	900	64EA24-170	900	64EA34-170	900	670
			1500#		64EA15-170	1500	64EA25-170	1500	64EA35-170	1500	1115
F	0.371	1 1/2 X 2	300#	150#	64FA12-170	300	64FA22-170	300	64FA32-170	300	225
			600#		64FA13-170	600	64FA23-170	600	64FA33-170	600	445
			900#		64FA14-170	900	64FA24-170	900	64FA34-170	900	670
			1500#		64FA15-170	1500	64FA25-170	1500	64FA35-170	1500	1115
G	0.559	1 1/2 X 3	300#	150#	64GA12-170	300	64GA22-170	300	64GA32-170	300	225
			600#		64GA13-170	600	64GA23-170	600	64GA33-170	600	445
			900#		64GA14-170	900	64GA24-170	900	64GA34-170	900	670
			1500#		64GA15-170	1500	64GA25-170	1500	64GA35-170	1500	1115
H	0.873	1 1/2 X 3	300#	150#	64HA12-170	300	64HA22-170	300	64HA32-170	300	225
			600#		64HA13-170	600	64HA23-170	600	64HA33-170	600	445
			900#		64HA14-170	900	64HA24-170	900	64HA34-170	900	670
			1500#		64HA15-170	1500	64HA25-170	1500	64HA35-170	1500	1115
J	1.430	2 X 3	300#	150#	64JA12-170	300	64JA22-170	300	64JA32-170	300	225
		600#	64JA13-170		600	64JA23-170	600	64JA33-170	600	445	
		2 1/2 X 4	900#	150#	64JA14-170	900	64JA24-170	900	64JA34-170	900	670
			1500#		64JA15-170	1500	64JA25-170	1500	64JA35-170	1500	1115
K	2.042	2 1/2 X 4	300#	150#	64KA12-170	300	64KA22-170	300	64KA32-170	300	225
			600#		64KA13-170	600	64KA23-170	600	64KA33-170	600	445
			900#		64KA14-170	900	64KA24-170	900	64KA34-170	900	670
			1500#		64KA15-170	1500	64KA25-170	1500	64KA35-170	1500	1115
L	3.170	3 X 6	300#	150#	64LA12-170	300	64LA22-170	300	64LA32-170	300	225
			600#		64LA13-170	600	64LA23-170	600	64LA33-170	600	445
			900#		64LA14-170	900	64LA24-170	900	64LA34-170	900	670
			1500#		64LA15-170	1500	64LA25-170	1500	64LA35-170	1500	1115
M	4.000	3 X 6	300#	150#	64MA12-170	300	64MA22-170	300	64MA32-170	300	225
			600#		64MA13-170	600	64MA23-170	600	64MA33-170	600	445
			900#		64MA14-170	900	64MA24-170	900	64MA34-170	900	670
			1500#		64MA15-170	1500	64MA25-170	1500	64MA35-170	1500	1115
N	4.822	4 X 6	300#	150#	64NA12-170	300	64NA22-170	300	64NA32-170	300	225
			600#		64NA13-170	600	64NA23-170	600	64NA33-170	600	445
			900#		64NA14-170	900	64NA24-170	900	64NA34-170	900	670
P	7.087	4 X 6	300#	150#	64PA12-170	300	64PA22-170	300	64PA32-170	300	225
			600#		64PA13-170	600	64PA23-170	600	64PA33-170	600	445
			900#		64PA14-170	900	64PA24-170	900	64PA34-170	900	670

**General Notes:**

1. The 6400 Series comes standard with an open yoke and plain lifting lever.
2. For optional test gag, change the last digit of the three digit type number suffix to "1". Example: 64GA13-171 and 66LA12-141.

3. On certain sizes 150#RF inlet flanges are available. Consult the Factory.
4. Available in open lever design only. No plain cap or packed lever construction.
5. For optional ring joint inlet, change the first digit of suffix to "9". Example: 64LA15-970.
6. Consult the Factory for set pressures beyond those listed above.



# Selection Table: Series 6600, Closed Bonnet

Orifice		Valve Size Inlet x Outlet	ANSI Flange Class		Type Number	Max. Set Press. PSIG at 450°F	Type Number	Max. Set Press. PSIG at 800°F	Max. Back Press. PSIG at 100°F
Letter	Area Sq. In.		Inlet RF	Outlet RF					
D	0.150	1 X 2	300#	150#	66DA12-140	300	66DA22-140	300	285
			600#		66DA13-140	600	66DA23-140	600	
			900#		66DA14-140	900	66DA24-140	900	
			1500#		66DA15-140	1500	66DA25-140	1500	
E	0.225	1 X 2	300#	150#	66EA12-140	300	66EA22-140	300	285
			600#		66EA13-140	600	66EA23-140	600	
			900#		66EA14-140	900	66EA24-140	900	
			1500#		66EA15-140	1500	66EA25-140	1500	
F	0.371	1 1/2 X 2	300#	150#	66FA12-140	300	66FA22-140	300	285
			600#		66FA13-140	600	66FA23-140	600	
			900#		66FA14-140	900	66FA24-140	900	
			1500#		66FA15-140	1500	66FA25-140	1500	
G	0.559	1 1/2 X 3	300#	150#	66GA12-140	300	66GA22-140	300	285
			600#		66GA13-140	600	66GA23-140	600	
			900#		66GA14-140	900	66GA24-140	900	
			1500#		66GA15-140	1500	66GA25-140	1500	
H	0.873	1 1/2 X 3	300#	150#	66HA12-140	300	66HA22-140	300	285
			600#		66HA13-140	600	66HA23-140	600	
			900#		66HA14-140	900	66HA24-140	900	
			1500#		66HA15-140	1500	66HA25-140	1500	
J	1.430	2 X 3	150#	66JA12-140	300	66JA22-140	300	285	
		600#		66JA13-140	600	66JA23-140	600		
		2 1/2 X 4	150#	900#	66JA14-140	900	66JA24-140		900
				1500#	66JA15-140	1500	66JA25-140		1500
K	2.042	2 1/2 X 4	300#	150#	66KA12-140	300	66KA22-140	300	285
			600#		66KA13-140	600	66KA23-140	600	
			900#		66KA14-140	900	66KA24-140	900	
			1500#		66KA15-140	1500	66KA25-140	1500	
L	3.170	3 X 6	300#	150#	66LA12-140	300	66LA22-140	300	285
			600#		66LA13-140	600	66LA23-140	600	
			900#		66LA14-140	900	66LA24-140	900	
			1500#		66LA15-140	1500	66LA25-140	1500	
M	4.000	3 X 6	300#	150#	66MA12-140	300	66MA22-140	300	285
			600#		66MA13-140	600	66MA23-140	600	
			900#		66MA14-140	900	66MA24-140	900	
			1500#		66MA15-140	1500	66MA25-140	1500	
N	4.822	4 X 6	300#	150#	66NA12-140	300	66NA22-140	300	285
			600#		66NA13-140	600	66NA23-140	600	
			900#		66NA14-140	900	66NA24-140	900	
P	7.087	4 X 6	300#	150#	66PA12-140	300	66PA22-140	300	285
			600#		66PA13-140	600	66PA23-140	600	
			900#		66PA14-140	900	66PA24-140	900	

**General Notes:**

- 1 The 6600 Series comes standard with enclosed spring and packed lifting lever.
2. Optional cap constructions and accessories may be specified by changing the three digit type number suffix as follows.

3. For organic fluid vaporizer service, add "D" to the type number and specify a plain screwed cap. Example: 66NA12D-120.
4. On certain sizes, 150#RF inlet flanges are available. Consult the Factory.
5. For optional ring joint inlet, change the first digit of suffix to "9". Example: 66EA15-920.
6. Consult the Factory for set pressures beyond those listed above.

Option	Suffix	
	No Gag	With Gag
Screwed Cap	-120	-121
Packed Lever	-140	-141

# Steam Capacities: 3% Overpressure

ASME Pressure Vessel Code (V) Stamp Capacities in Pounds Per Hour at Saturation Temperature



Set Pressure (psig)	D 0.150	E 0.225	F 0.371	G 0.559	H 0.873	J 1.430	K 2.042	L 3.170	M 4.000	N 4.822	P 7.087
1 PSI INCR.	6.8	10.2	16.9	25.5	39.7	65	93	144	182	219	322
5 PSI INCR.	34	51	84	127	199	325	465	722	910	1097	1613
10 PSI INCR.	68	102	169	255	397	650	929	1443	1821	2195	3226
15	210	315	519	783	1222	2003	2860	4440	5602	6754	9926
20	243	364	601	906	1415	2318	3311	5140	6486	7819	11492
40	375	563	929	1400	2187	3582	5116	7942	10021	12081	17755
60	508	762	1257	1894	2958	4846	6920	10743	13556	16342	24018
80	643	965	1591	2398	3745	6135	8761	13601	17162	20689	30407
100	780	1170	1929	2907	4540	7437	10620	16486	20803	25078	36858
120	916	1374	2267	3416	5334	8738	12478	19372	24444	29467	43309
140	1053	1579	2604	3924	6129	10040	14337	22257	28085	33856	49760
160	1189	1784	2942	4433	6924	11342	16196	25143	31726	38246	56211
180	1326	1989	3280	4942	7718	12643	18054	28028	35367	42635	62661
200	1462	2194	3618	5451	8513	13945	19913	30914	39008	47024	69112
220	1599	2399	3955	5960	9308	15247	21772	33799	42649	51413	75563
240	1735	2603	4293	6469	10102	16548	23631	36685	46290	55802	82014
260	1872	2808	4631	6977	10897	17850	25489	39570	49931	60192	88465
280	2008	3013	4968	7486	11692	19152	27348	42456	53572	64581	94916
300	2145	3218	5306	7995	12486	20453	29207	45341	57213	68970	101367
320	2282	3423	5644	8504	13281	21755	31066	48227	60854	73359	107818
340	2418	3627	5981	9013	14076	23057	32924	51112	64495	77749	114269
360	2555	3832	6319	9522	14870	24358	34783	53998	68136	82138	120720
380	2691	4037	6657	10030	15665	25660	36642	56883	71777	86527	127171
400	2828	4242	6995	10539	16460	26962	38501	59769	75418	90916	133622
420	2964	4447	7332	11048	17254	28263	40359	62654	79059	95306	140073
440	3101	4651	7670	11557	18049	29565	42218	65540	82700	99695	146524
460	3237	4856	8008	12066	18844	30867	44077	68425	86341	104084	152975
480	3374	5061	8345	12575	19638	32168	45936	71311	89982	108473	159426
500	3510	5266	8683	13083	20433	33470	47794	74196	93623	112863	165877
520	3647	5471	9021	13592	21227	34772	49653	77082	97264	117252	172328
540	3783	5675	9358	14101	22022	36073	51512	79967	100905	121641	178779
560	3920	5880	9696	14610	22817	37375	53370	82853	104546	126030	185230
580	4057	6085	10034	15119	23611	38677	55229	85738	108187	130419	191681
600	4193	6290	10372	15628	24406	39978	57088	88624	111828	134809	198132
620	4330	6495	10709	16136	25201	41280	58947	91509	115469	139198	204583
640	4466	6699	11047	16645	25995	42581	60805	94395	119110	143587	211033
660	4603	6904	11385	17154	26790	43883	62664	97280	122751	147976	217484
680	4739	7109	11722	17663	27585	45185	64523	100166	126392	152366	223935
700	4876	7314	12060	18172	28379	46486	66382	103051	130033	156755	230386
720	5012	7519	12398	18681	29174	47788	68240	105937	133674	161144	236837
740	5149	7723	12736	19189	29969	49090	70099	108822	137315	165533	243288
760	5285	7928	13073	19698	30763	50391	71958	111708	140956	169923	249739
780	5422	8133	13411	20207	31558	51693	73817	114593	144597	174312	256190
800	5558	8338	13749	20716	32353	52995	75675	117479	148238	178701	262641
820	5695	8543	14086	21225	33147	54296	77534	120364	151879	183090	269092
840	5832	8748	14424	21733	33942	55598	79393	123250	155520	187480	275543
860	5968	8952	14762	22242	34737	56900	81251	126135	159161	191869	281994
880	6105	9157	15099	22751	35531	58201	83110	129021	162802	196258	288445
900	6241	9362	15437	23260	36326	59503	84969	131906	166443	200647	294896
920	6378	9567	15775	23769	37120	60805	86828	134792	170084	—	—
940	6514	9772	16113	24278	37915	62106	88686	137677	173725	—	—
960	6651	9976	16450	24786	38710	63408	90545	140563	177366	—	—
980	6787	10181	16788	25295	39504	64710	92404	143448	181007	—	—
1000	6924	10386	17126	25804	40299	66011	94263	146334	184648	—	—
1100	7607	11410	18814	28348	44272	72520	103556	160761	202853	—	—
1200	8289	12434	20503	30892	48246	79028	112850	175189	221058	—	—
1300	8972	13458	22191	33437	52219	85536	122144	189616	239263	—	—
1400	9655	14482	23880	35981	56192	92045	131437	204044	257468	—	—
1500	10337	15506	25568	38525	60165	98553	140731	218471	275673	—	—





# Dimensions & Weight

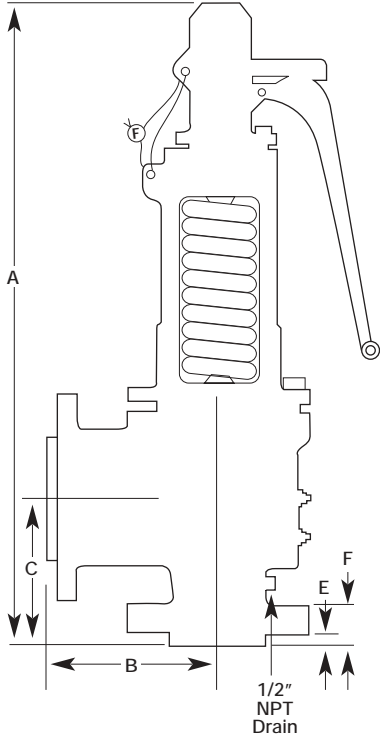

Valve Size Inlet x Outlet	Type Number	ANSI Flange Class		Dimensions in Inches					Approx. Weight Lbs.
		Inlet RF	Outlet RF	A (Max)	B	C	E	F	
1 X 2	64DA12-170	300#	150#	18 7/8	4 1/2	4 1/8	1/2	1 1/4	42
	64DA13-170	600#			4 1/2	4 1/8	1/2	1 1/4	42
	64DA14-170	900#			4 1/2	4 1/8	1/2	1 11/16	48
	64DA15-170	1500#			4 1/2	4 1/8	1/2	1 11/16	48
1 X 2	64EA12-170	300#	150#	18 7/8	4 1/2	4 1/8	1/2	1 1/4	42
	64EA13-170	600#			4 1/2	4 1/8	1/2	1 1/4	42
	64EA14-170	900#			4 1/2	4 1/8	1/2	1 11/16	48
	64EA15-170	1500#			4 1/2	4 1/8	1/2	1 11/16	48
1 1/2 X 2	64FA12-170	300#	150#	22 3/4	6	4 7/8	11/16	1 5/8	50
	64FA13-170	600#			6	4 7/8	11/16	1 5/8	50
	64FA14-170	900#			6	4 7/8	11/16	2	60
	64FA15-170	1500#			6	4 7/8	11/16	2	60
1 1/2 X 3	64GA12-170	300#	150#	22 7/8	5 1/8	5 1/8	11/16	1 5/8	60
	64GA13-170	600#			5 1/8	5 1/8	11/16	1 5/8	60
	64GA14-170	900#			5 1/8	5 1/8	11/16	2	60
	64GA15-170	1500#			5 1/8	5 1/8	11/16	2	85
1 1/2 X 3	64HA12-170	300#	150#	22 7/8	5 1/8	5 1/8	11/16	1 5/8	70
	64HA13-170	600#			5 1/8	5 1/8	11/16	1 5/8	70
	64HA14-170	900#			5 1/8	5 1/8	11/16	2	70
	64HA15-170	1500#			5 1/8	5 1/8	11/16	2	85
2 X 3	64JA12-170	300#	150#	23 7/8	6 3/8	6 1/16	11/16	1 3/4	70
	64JA13-170	600#			6 3/8	6 1/16	11/16	1 3/4	70
2 1/2 X 4	64JA14-170	900#	150#	33 3/8	6 3/4	6 1/8	11/16	2 3/8	70
	64JA15-170	1500#			6 3/4	6 1/8	11/16	2 3/8	85
2 1/2 X 4	64KA12-170	300#	150#	33 1/2	6 3/4	6 1/8	11/16	1 7/8	150
	64KA13-170	600#			6 3/4	6 1/8	11/16	1 7/8	150
	64KA14-170	900#			6 3/4	6 1/8	11/16	2 3/8	150
	64KA15-170	1500#			6 3/4	6 1/8	11/16	2 3/8	175
3 X 6	64LA12-170	300#	150#	36 5/8	8 1/2	7 13/16	11/16	2	230
	64LA13-170	600#			8 1/2	7 13/16	11/16	2	230
	64LA14-170	900#			8 1/2	7 13/16	11/16	2 5/8	230
	64LA15-170	1500#			8 1/2	7 13/16	11/16	2 5/8	250
3 X 6	64MA12-170	300#	150#	36 5/8	8 1/2	7 13/16	11/16	2	230
	64MA13-170	600#			8 1/2	7 13/16	11/16	2	230
	64MA14-170	900#			8 1/2	7 13/16	11/16	2 5/8	230
	64MA15-170	1500#			8 1/2	7 13/16	11/16	2 5/8	250
4 X 6	64NA12-170	300#	150#	42 3/8	10	8 7/8	11/16	2	230
	64NA13-170	600#			10	8 7/8	11/16	2 1/4	250
	64NA14-170	900#			10	8 7/8	11/16	2 1/2	250
4 X 6	64PA12-170	300#	150#	42 3/8	10	8 7/8	11/16	2	230
	64PA13-170	600#			10	8 7/8	11/16	2 1/4	250
	64PA14-170	900#			10	8 7/8	11/16	2 1/2	250

Above dimensions also apply to the 6600 Series with closed bonnet.



10195 Brecksville Road, Brecksville, OH 44141 USA • Telephone: 440/838-7690 • Fax: 440/838-7699 • www.cwfc.com

Facilities: Brecksville, OH USA, E. Farmingdale, NY USA, Brantford, Ontario Canada, Bridport, UK

Offices: worldwide. For a listing of our global sales network, visit our website at www.cwfc.com.

While this information is presented in good faith and believed to be accurate, Farris Engineering does not guarantee satisfactory results from reliance upon such information. Nothing contained herein is to be construed as a warranty or guarantee, expressed or implied, regarding the performance, merchantability, fitness or any other matter with respect to the products, nor as a recommendation to use any product or process in conflict with any patent. Farris Engineering reserves the right, without notice, to alter or improve the designs or specifications of the products described herein.